



Key Features

Distributed Services Architecture

- Coarse-Grained Service Model
- Distributed, Dynamic Deployment and Management
- Event-Driven Process Orchestration
- Lifecycle Management and Versioning
- XML Transformations
- B2B gateway

Peer-to-Peer Communications Backbone

- Unbounded Performance and Scalability
- Service-Level Failover and 24x7xForever Availability
- Comprehensive Security

Generic Services and Adapters

- Monitoring, Logging and Auditing
- Adapters and Pre-built Services

Supported Standards

- JMS, JCA, JMX
- XML, XSLT, Xpath, XQuery
- Web Services - WSDL, UDDI, SOAP, REST
- Security - SSL, JAAS, JSSE
- J2EE, .NET, HTTP, JDBC, EDI

Fiorano SOA Platform®

Real-Time Business Platform on a Standards-Based ESB

Fiorano SOA is a platform for deploying service-oriented applications that allows companies to integrate applications and deploy business processes across the extended enterprise using a standards-based, componentized approach. With a highly distributed, yet centrally managed architecture, Fiorano SOA enables companies to draw on existing business logic residing anywhere within the enterprise to rapidly assemble efficient solutions for business problems. The platform's event-driven architecture allows improved responsiveness to changing business conditions, leading to unmatched flexibility and increased productivity. The proven market leader, Fiorano SOA has been deployed in large-scale, secure, mission-critical environments, enabling effective reuse and allowing projects to be incrementally scaled and extended across the enterprise.

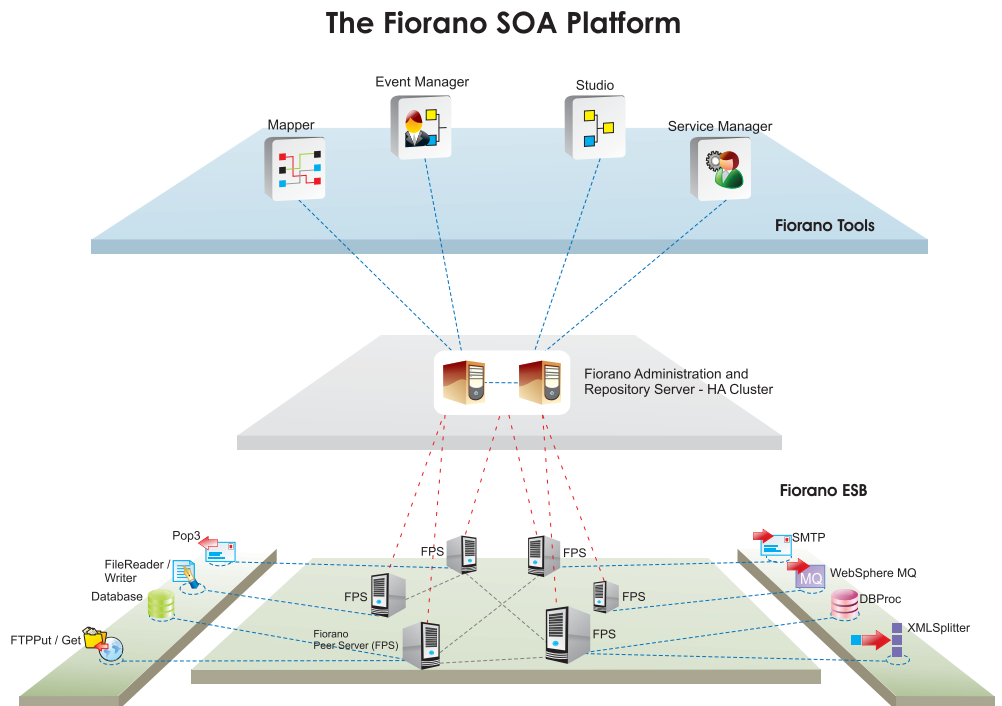

The Fiorano ESB serves as the foundation of the Fiorano SOA Platform which adds the Fiorano Process Orchestration Tools and Fiorano Components & Adapters to form a comprehensive platform for enterprises to achieve a quick path to a Service Oriented Architecture (SOA).



The proven leader in large-scale, mission-critical deployments, the Fiorano platform was architected with reliability and flexibility in mind, allowing a logical application design to be mapped directly to the physical implementation, making the development process more intuitive and easier than that of conventional integration suites. Key features and benefits include:

Distributed Services Architecture

Coarse-Grained Service Model

Fiorano SOA uniquely defines a coarse-grained service model that simplifies the componentization of business-logic, automatically enhancing reuse and optimizing performance.

Dynamic Service Deployment and Management

Enables service deployment across the distributed infrastructure from any centralized location, allowing each individual service to be independently configured, managed, updated and redeployed without disrupting other services.

Message/Event-Driven Process Orchestration

By automatically configuring the underlying middleware, allows the logical process design to be mapped directly to physical services distributed across the ESB, empowering non-technical business-users to compose, deploy and modify event-driven business processes.

Lifecycle Management and Versioning

Enables controlled deployment of business services across network end-points, together with automatic transitions across the software lifecycle (development, QA, staging, and production).

XML Transformations

Supports sophisticated XSLT transformations with pluggable external transformation engines, using visual tools. Enables assertion-based verification of processes via XSD port matching.

Peer-to-Peer, REST-based Communications Backbone

Unbounded Performance and Scalability

Peer-to-peer messaging obviates the need for events to traverse a central hub, enabling concurrent event flows between distributed services, obviating any single points of failure within the infrastructure.

Service-Level Failover and 24x7xForever Availability

Enables failover instances of services to be dynamically deployed on remote ESB nodes based on multiple triggers, creating self-healing application networks with continuous availability under all operating environments.

Comprehensive Security

Provides a flexible framework for authentication, authorization and encryption with support for J2EE, LDAP and other security standards; adapting to a wide range of federated enterprise security policies.

Generic Services and Adapters

Monitoring, Logging and Auditing

Supports asynchronous event-based notification of critical errors in event driven business processes, with dynamic tracing, logging, auditing and monitoring of messages, documents and services.

Adapters and Pre-built Services

Ships with a rich set of pre-built services including adapters to all popular relational databases, files, Messaging Middleware (IBM WebSphere MQ, JMS, MSMQ, others), Web Services, EJB, FTP, SMTP and more.

Advantages of a Standards-based Solution

The Fiorano SOA platform implements standards for communication, connectivity, transformation and security, enabling application interoperability and allowing skills and software-assets to be easily transferred between projects. Fiorano supports and drives industry standards for integration, including Java, Web Services, and XML.

Mitigating Proprietary Dependencies

Proprietary integration solutions 'lock-in' customers by forcing them to code to non-standard APIs, inhibiting flexibility, preventing reuse and ultimately proving to be extremely expensive. Fiorano's standards-based, service-oriented approach smoothens the operational path of the processes running a business, reducing the time, effort and cost of integrating applications.

Reuse of Software Assets

The adoption of a standards-based, Service Oriented Architecture (SOA) allows existing legacy and packaged applications within an organization to be used as building blocks, enabling their reuse within enterprise business processes, driving down development and management costs. With a quicker learning curve, standards further enable development skills and resources to be effectively reused across projects.

Seamless Connectivity

The emergence of connectivity standards including Web-Services, JMS, JCA and .NET allow Fiorano SOA to seamlessly integrate multiple enterprise assets including application servers, messaging middleware, legacy systems and mainframe applications, without requiring custom coding or application rewrites; standards shield users from version and API changes, ensuring that existing processes are not disrupted by new releases.

Easy Interoperability

Support for Web Services and other standards within Fiorano SOA enables seamless interoperability of disparate applications distributed across heterogeneous platforms; applications can now exchange data with ease, without the need for expensive custom transformations, extra coding or language translation capabilities.



Fiorano SOA Business Benefits

Fiorano SOA offers a number of benefits over existing solutions for integration and real-time enablement, including faster implementation and deployment cycles, a flexible platform for future expansion offering a high degree of reuse, easy extensibility, seamless interoperability and an improved ROI. Key advantages include:

Dynamic Responsiveness

Deployed as service-oriented processes, solutions on the Fiorano SOA platform improve responsiveness to changing business requirements, minimizing impact on existing business applications and often eliminating the need for new packaged applications. Fiorano SOA is based on an event-driven, asynchronous, message-based service-oriented architecture, providing the ability to rapidly specify controlled changes to operations based on business objectives, and to implement these changes directly, quickly and more efficiently for business agility and integrity.

Reduced Training Costs

Fiorano SOA improves the productivity of organizations by including a variety of pre-built services necessary for the creation of service-oriented processes, together with tools to componentize existing enterprise software assets. Comprehensive support for industry standards, including J2EE, .NET, XML and Web-Services, ensure a fast learning curve, allowing developers and even enterprise managers to quickly become proficient at synthesizing custom solutions to problems in the form of interactive service-oriented processes.

Increased Revenue

With in-built support for business-to-business interactions, Fiorano SOA enables seamless connectivity across the extended enterprise for transacting business in real-time with customers, trading partners and distributors worldwide. Streamlined processes translate into increased revenue, lower costs and open up possibilities of innovation to find newer sources of revenue. Fiorano SOA's architectural-level innovations enable linear, build-as-you-grow scalability.

Accelerated Time to Market

Fiorano SOA enables the creation of interactive, end-user service-oriented processes without programming, by orchestrating existing services with visual tools. The ability to synthesize applications from multiple, distributed enterprise assets without any programming is extremely vital for achieving flexibility in a dynamic environment, leading to the automation of common development tasks and accelerated time-to-market.

Lower Total Cost of Ownership

Fiorano SOA is built on top of standards, enabling efficient reuse of existing enterprise applications and infrastructure and lowering capital requirements for new projects. B2B features lower cost of working capital compressing order to cash times. Fiorano SOA's dynamic versioning, deployment, and change-management capabilities, reduce development and maintenance costs by an order of magnitude in comparison to incumbent solutions.

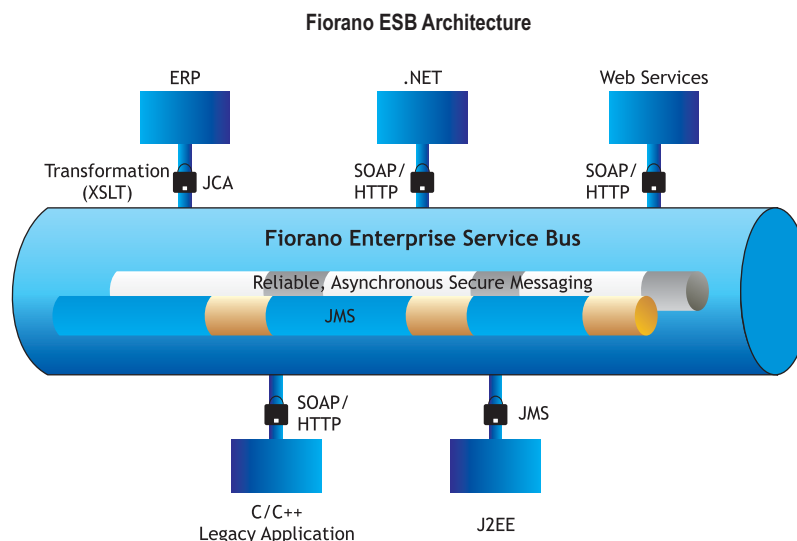

The Enterprise Service Bus - Enabling Standards-Based Integration

An ESB is a foundation for an enterprise-wide SOA, allowing enterprises to integrate applications and processes as standards-based, event-driven services over a highly distributed, centrally managed infrastructure. With no single point of failure, ESBs are inherently reliable and linearly scalable and have no performance bottlenecks. ESB Services (including application/business logic as well as fundamental transformation, routing, connectivity and distribution services) may be deployed and managed from any physical location across the enterprise network. Built entirely on industry standards including XML and Web Services, ESBs enable the next wave of comprehensive and affordable integration solutions, unifying applications and infrastructure within and across the extended enterprise and delivering the value IT departments are looking for via reuse, flexibility and faster time to market.



Global Leaders Choose Fiorano

Fiorano helps organizations worldwide improve operational efficiencies and business performance by sharing information dynamically across global operations. Our commitment to developing standards based solutions that deliver immediate ROI with proven interoperability and industry-leading reliability helps ensure our customers' sustained success in worldwide markets. Fiorano understands the development, infrastructure and performance challenges facing IT departments in today's hyper-competitive markets. Over 500 enterprises worldwide have deployed Fiorano solutions, allowing them to:

- Extract business value from existing business and legacy applications spanning multiple, cross organizational boundaries;
- Deploy in a cost effective, incremental fashion, without disrupting existing operations or major up-front investments;
- Meet dynamic surges in demand, deliver services without disruption and increase customer satisfaction without having to provision new hardware systems;
- Lower the cost of ownership and maintenance of IT systems via enhanced reuse of software assets and standards based implementations;
- Reduce training costs and reliance on outside consultants, allowing in-house developers to deploy and manage complex integrations;
- Enhance productivity by allowing business-analysts to compose business processes with minimal programmer intervention.

Product Bundle

- Fiorano Enterprise Server
- Fiorano Peer Server
- Fiorano SOA Studio
- Fiorano SOA Visual Tools
- Fiorano Business Services/ Adapters

Supported Platforms

- Sun Solaris
- Microsoft Win 32
- IBM AS 400
- HP-UX
- Linux
- Apple Macintosh

Manufacturing

Leading manufacturers have selected Fiorano over competing solutions for real-time process control across multiple platforms and applications over heterogeneous protocols.

Energy

Some of the largest oil and energy companies use Fiorano to rapidly integrate disparate systems and harness silos of information in legacy systems to improve delivery of services. Oil companies use Fiorano to get real time information from field to office enabling critical decision making by Managers that directly impacts the bottom line.

Banking and Financial Services

Leading financial institutions have selected Fiorano solutions to deploy the next wave of flexible and adaptable core banking, risk management and trading solutions.

Telecommunications

Leading telecommunications companies use Fiorano Software to deliver millions of messages daily across complex, distributed workflows in mission-critical 24x7 environments

Retail, Real Estate and Hospitality

Some of the leading consumer service organizations use Fiorano to significantly improve their net profits through streamlining of processes and connecting with trading partners.

Government /Defense

State and Federal Governments have deployed Fiorano to significantly improve citizen services and increase revenue collections; Defense Agencies have used the solutions to significantly enhance their response and intelligence gathering activities.

ABOUT FIORANO SOFTWARE

Founded in 1995, Silicon Valley based Fiorano is a USA (California) Corporation, a trusted provider of Digital Business Backplane and enterprise integration middleware, high performance messaging and peer-to-peer distributed systems. Fiorano powers real time, digital enterprises with bimodal integration and API Management strategy that leverages the best of systematic (centralized, high-control) and adaptive (federated, high-speed) approaches to deliver solutions across cloud, on-premise and hybrid environments.

Global leaders including AT&T Wireless, Boeing, British Telecom, Capgemini Telecom, Federal Bank, L'Oréal, McKesson, NASA, POSCO, Rabobank, Royal Bank of Scotland, Schlumberger, US Coast Guard and Vodafone have deployed Fiorano to drive innovation through open, standards-based, event-driven real-time solutions yielding unprecedented productivity.

AMERICAS

Fiorano Software, Inc.
230 S. California Avenue,
Suite 103, Palo Alto, CA 94306 USA
Tel: +1 650 326 1136
Fax: +1 646 607 5875
Toll-Free: +1 800 663 3621
Email: info@fiorano.com

EMEA

Fiorano Software Ltd
3000 Hillswood Drive
Hillswood Business Park
Chertsey Surrey KT16 0RS UK
Tel: +44 (0) 1932 895005
Fax: +44 (0) 1932 325413
Email: info_uk@fiorano.com

APAC

Fiorano Software Pte. Ltd.
Level 42, Suntec Tower Three
8 Temasek Boulevard
038988 Singapore
Tel: +65 68292234
Fax: +65 68264015
Email: info_asiapac@fiorano.com

www.fiorano.com